

Revelator 5 1/4" Midwoofer



Type Number: 15S/8531K01

Features:

The Revelator series has for years been celebrated for producing the best sounding electro dynamic transducers in the world. Since ScanSpeak was founded in 1970, the audio engineers and R&D experts working on the line have been on a quest to create drivers that reveal all the sound in recordings, hiding nothing from the listener. This quest has resulted in several revolutionary inventions that remove distortion in the magnet systems and in the moving parts of the speaker. The philosophy is that the sound has to be very dynamic, giving a perfect transient response and providing tonal balance.

One of the latest inventions realized in the Revelator midrange design is the sliced paper (or wood) cone, which reduces break-up modes in the membrane dramatically. The result is an undisputed clarity in sound.

Driver Highlights: Low loss linear suspension, sliced paper cone, SD-1 motor, shielded



Specs:

Electrical Data

Nominal impedance	Zn 8 ohm
Minimum impedance	Zmin -- ohm
Maximum impedance	Zo -- ohm
DC resistance	Re 5.8 ohm
Voice coil inductance	Le 0.35 mH

T-S Parameters

Resonance Frequency	fs 32 Hz
Mechanical Q factor	Qms 5
Electrical Q factor	Qes 0.42
Total Q factor	Qts 0.39
Force factor	Bl 5.9 Tm
Mechanical resistance	Rms 0.5 Kg/s
Moving mass	Mms 12.5 g
Suspension compliance	Cms -- mm/N
Effective cone diameter	D -- cm
Effective piston area	Sd 95 cm ²
Equivalent volume	Vas 25.3 ltrs
Sensitivity (2.83V/1m)	84.5 dB
Ratio BL/ (Re)	--
Ratio fs/Qts	F --

Power handling

100h RMS noise test (IEC)	60 W
Long-term Max Power (IEC 18.3)	-- W
Max linear SPL (rms) @ power	-- dB/W
Short Term Max power (IEC 18.2)	-- W

Voice Coil and Magnet Parameters

Voice coil diameter	38 mm
Voice coil height	-- mm
Voice coil layers	--
Height of the gap	-- mm
Linear excursion +/-	6.5 mm
Max mech. excursion +/-	11 mm
Flux density of gap	-- mWb
Total useful flux	-- mWb
Diameter of magnet	-- mm
Height of magnet	-- mm
Weight of magnet	-- Kg

Notes:
IEC specs refer to IEC 60268-5 third edition.
All ScanSpeak products are RoHS compliant.

Frequency: 15S/8531K01

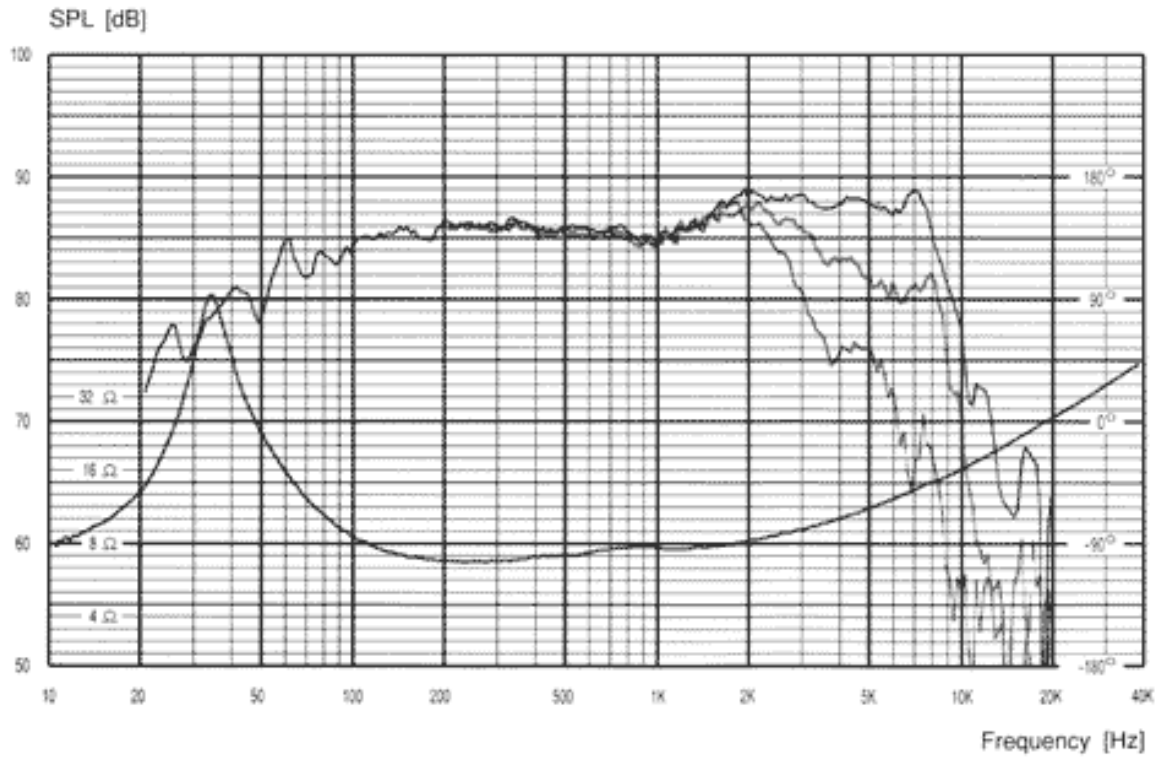

Mechanical Dimensions:15S/8531K01

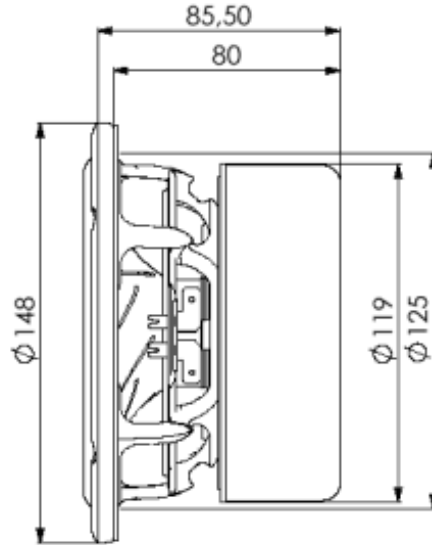
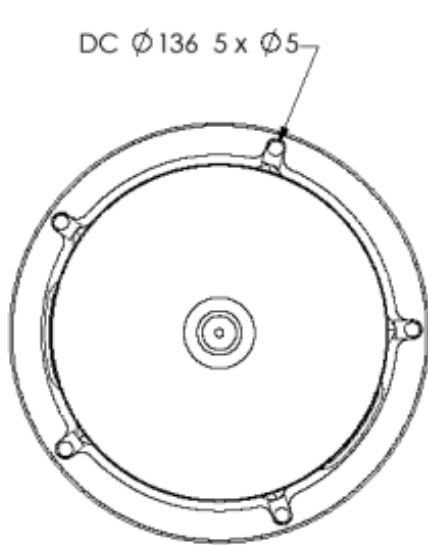

- Drawing Dimensions**
- Outside Diameter
 - Flange Thickness
 - Magnet Diameter
 - Cutout Diameter
 - Interior Depth
 - Hole Diameter
 - Screw Circle Diameter