

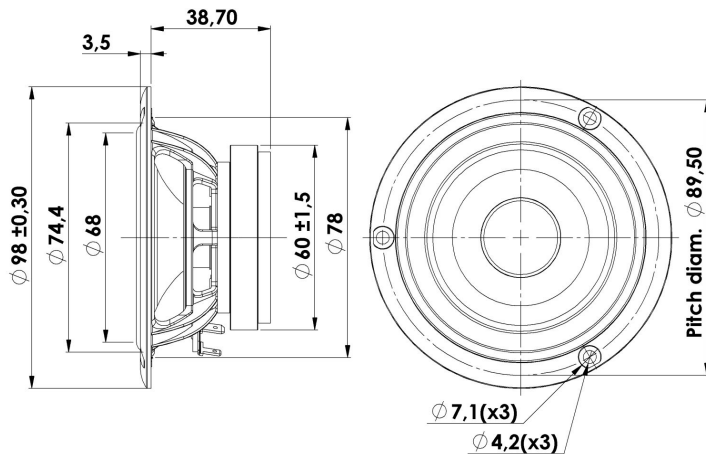

## FULLRANGE

## 10F/8422-03

This superior fullrange speaker is exclusively designed and made for STEREO magazine. It offers a design based on a class leader for more than 20 years on the market, known for a natural and pleasant sound. The basket installs flush to the baffle. For better performance, keep rear side free of edge reflections. Suitable for many types of design, including closed box, reflex box, transmission line and horn speakers.



### KEY FEATURES:

- Very wide Frequency Range
- Ventilation below spider
- Copper Cap on Pole Piece

- Coated Paper Cone w. NRSC (patented)
- SBR Rubber Surround
- Signature: logo print on back plate

#### T-S Parameters

Resonance frequency [fs]	100 Hz
Mechanical Q factor [Qms]	2.4
Electrical Q factor [Qes]	0.76
Total Q factor [Qts]	0.58
Force factor [Bl]	3.4 Tm
Mechanical resistance [Rms]	0.6 kg/s
Moving mass [Mms]	2.3 g
Compliance [Cms]	1.1 mm/N
Effective diaph. diameter [D]	68 mm
Effective piston area [Sd]	36.3 cm <sup>2</sup>
Equivalent volume [Vas]	2.1 l
Sensitivity (2.83V/1m)	84 dB
Ratio Bl/√Re	1.37 N/√W
Ratio fs/Qts	173 Hz

#### Notes:

IEC specs. refer to IEC 60268-5 third edition.  
All Scan-Speak products are RoHS compliant.  
Data are subject to change without notice.  
Datasheet updated: March 7, 2012.

#### Electrical Data

Nominal impedance [Zn]	8 Ω
Minimum impedance [Zmin]	6.5 Ω
Maximum impedance [Zo]	15.1 Ω
DC resistance [Re]	6.2 Ω
Voice coil inductance [Le]	0.12 mH

#### Power Handling

100h RMS noise test (IEC 17.1)	15 W
Long-term max power (IEC 17.3)	30 W

#### Voice Coil & Magnet Data

Voice coil diameter	19.4 mm
Voice coil height	8.7 mm
Voice coil layers	2
Height of gap	4 mm
Linear excursion	± 2.3 mm
Max mech. excursion	± 7 mm
Unit weight	0.27 kg



## FULLRANGE

10F/8422-03

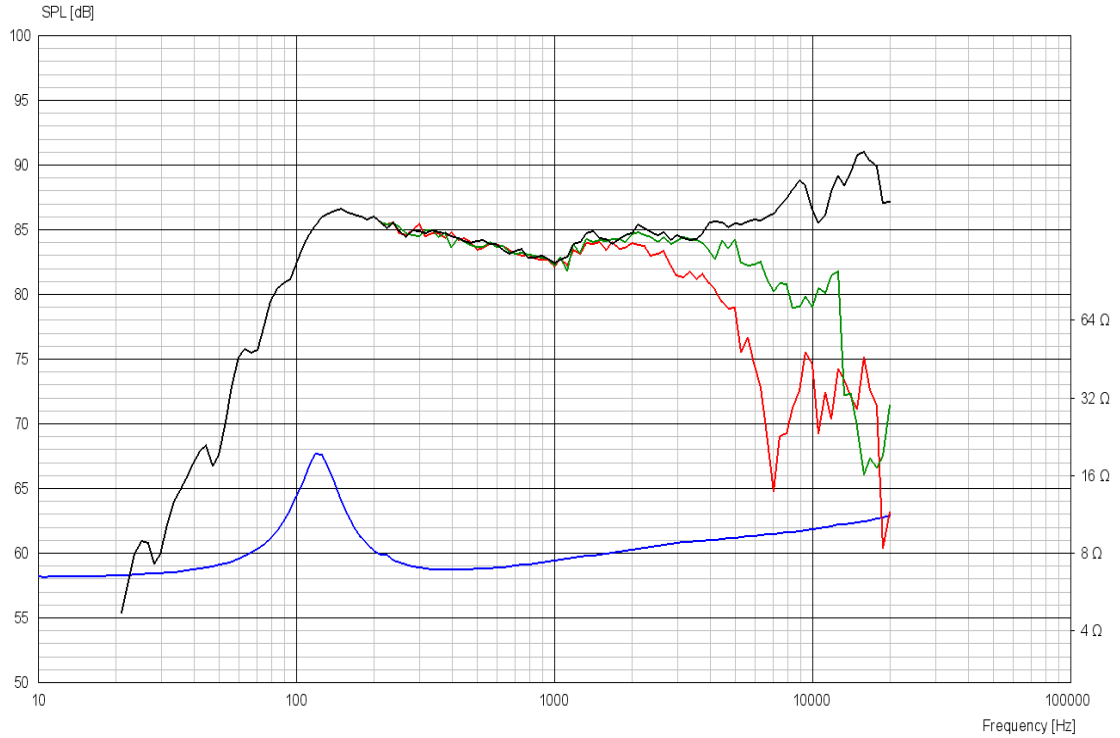

## Advanced Parameters (Preliminary)

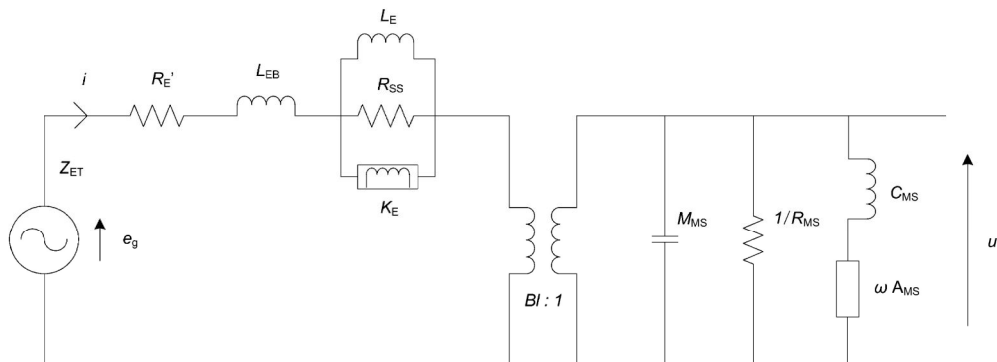

### Electrical data

Resistance [Re']	6.38 Ω
Free inductance [Leb]	0.0350 mH
Bound inductance [Le]	0.529 mH
Semi-inductance [Ke]	0.0414 SH
Shunt resistance [Rss]	4.39 Ω

### Mechanical Data

Force Factor [Bl]	2.83 Tm
Moving mass [Mms]	2.50 g
Compliance [Cms]	0.959 mm/N
Mechanical resistance [Rms]	0.403 kg/s
Admittance [Ams]	0.118 mm/N