

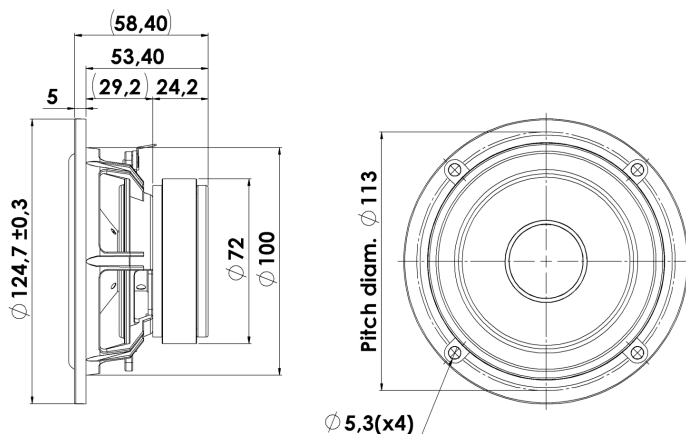

MIDWOOFER

12W/8524G00

The Discovery series offer traditional design, superior sound, a solid construction, and a wide range of variants. Combining these elements - plus a wealth of technical features and finesses - it gives our customers the possibility of acquiring a tailor-made Scan-Speak solution with very good performance at a reasonable low price point!



KEY FEATURES:

- Wide Operating Frequency Range
- Coated NRSC Fibre Glass Cone (patent)
- Die cast Alu Chassis vented below spider
- Suitable for 2-way or 3-way (as midrange)
- Low Damping SBR Rubber Surround

T-S Parameters

Resonance frequency [fs]	52 Hz
Mechanical Q factor [Qms]	3.42
Electrical Q factor [Qes]	0.35
Total Q factor [Qts]	0.32
Force factor [Bl]	5.4 Tm
Mechanical resistance [Rms]	0.54 kg/s
Moving mass [Mms]	5.6 g
Compliance [Cms]	1.67 mm/N
Effective diaph. diameter [D]	86 mm
Effective piston area [Sd]	59 cm ²
Equivalent volume [Vas]	8.2 l
Sensitivity (2.83V/1m)	85.8 dB
Ratio Bl/√Re	2.28 N/√W
Ratio fs/Qts	163 Hz

Notes:

IEC specs. refer to IEC 60268-5 third edition.
All Scan-Speak products are RoHS compliant.
Data are subject to change without notice.
Datasheet updated: January 30, 2013.

Electrical Data

Nominal impedance [Zn]	8 Ω
Minimum impedance [Zmin]	6.6 Ω
Maximum impedance [Zo]	48.2 Ω
DC resistance [Re]	5.7 Ω
Voice coil inductance [Le]	0.6 mH

Power Handling

100h RMS noise test (IEC 17.1)	40 W
Long-term max power (IEC 17.3)	70 W

Voice Coil & Magnet Data

Voice coil diameter	25 mm
Voice coil height	10 mm
Voice coil layers	2
Height of gap	4 mm
Linear excursion	± 3 mm
Max mech. excursion	± 9 mm
Unit weight	1 kg



MIDWOOFER

12W/8524G00

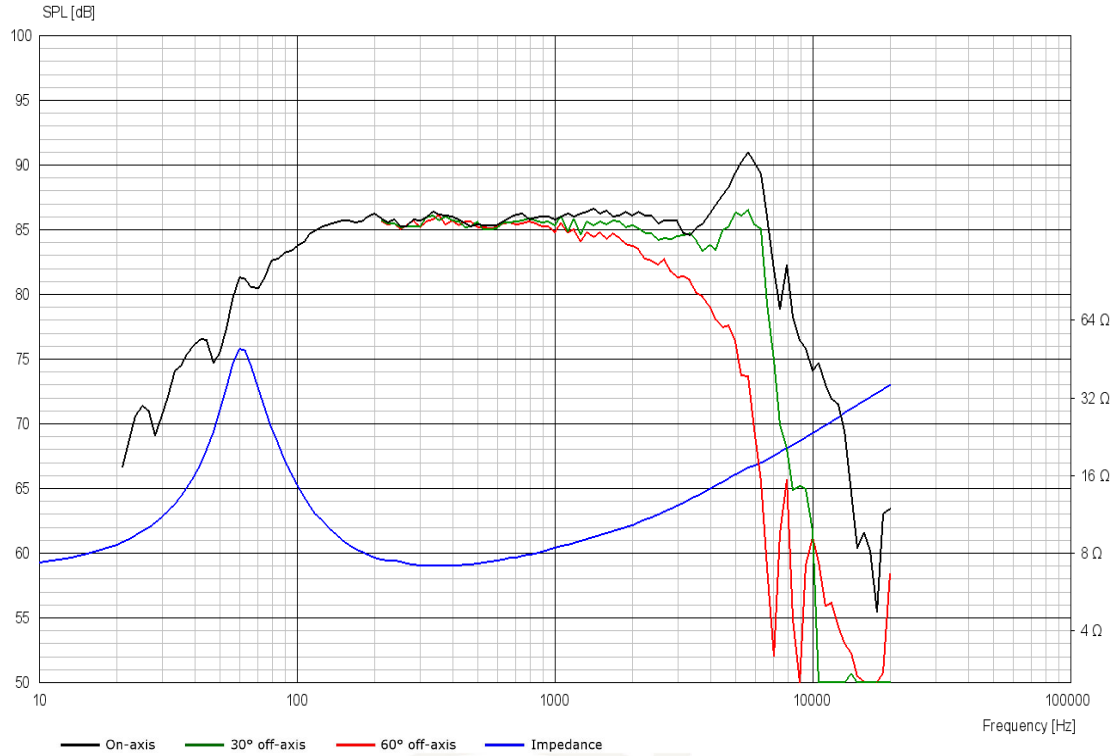

Advanced Parameters (Preliminary)

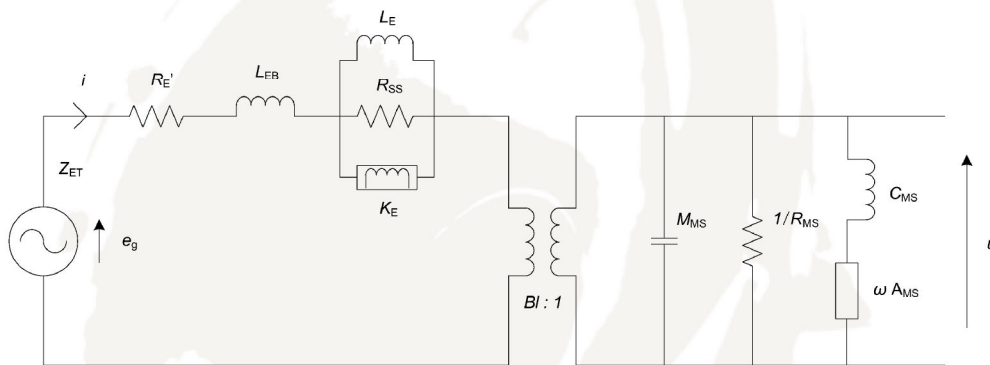

Electrical data

Resistance [$R_{E'}$]	5.78 Ω
Free inductance [L_{EB}]	0.093 mH
Bound inductance [L_E]	0.92 mH
Semi-inductance [K_E]	0.086 SH
Shunt resistance [R_{SS}]	205 Ω

Mechanical Data

Force Factor [BI]	5.43 Tm
Moving mass [M_{MS}]	6.0 g
Compliance [C_{MS}]	0.95 mm/N
Mechanical resistance [R_{MS}]	0.76 kg/s
Admittance [A_{MS}]	0.15 mm/N